

Art.-Nr. 10378



4 015862 034397

SOMMER Antriebs- und
Funktechnik GmbH

Hans-Böckler-Straße 27
73230 Kirchheim/Teck
Germany

+49 (0) 900 1800-150

• 0,14 €/min aus dem
deutschen Festnetz.
Mobilfunkpreise abweichend.

Contact info:

Coordonnées :

Informazioni di contatto:

Información de contacto:

info@sommer.eu
www.sommer.eu

© Copyright 2022
 Alle Rechte vorbehalten.
 All rights reserved.
 Tous droits réservés.
 Tutti i diritti riservati.
 Reservados todos los derechos.

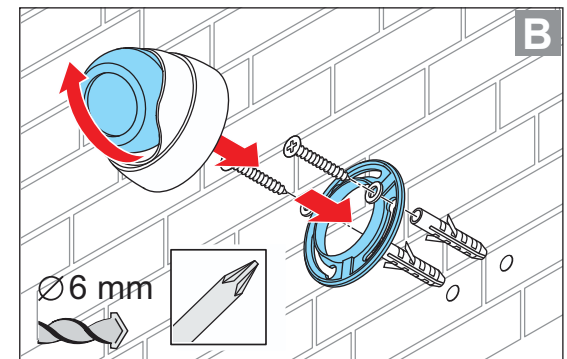
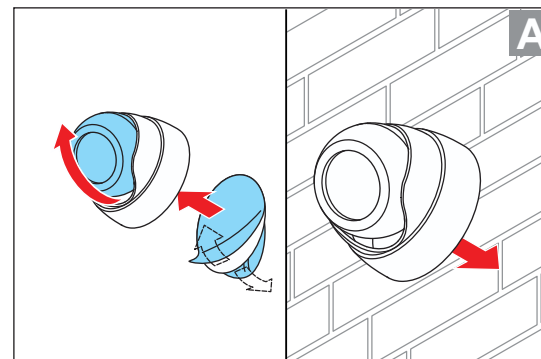
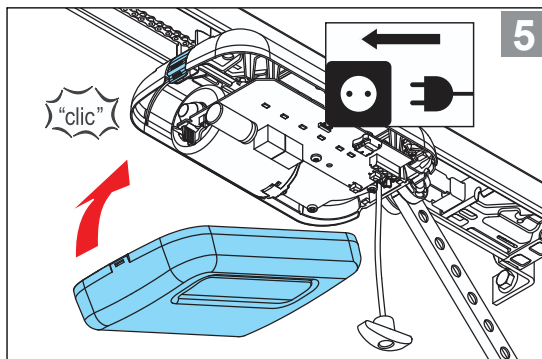
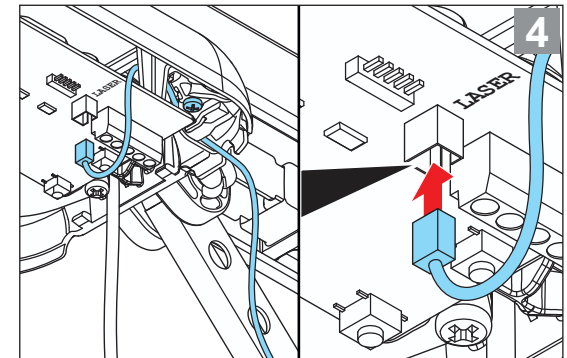
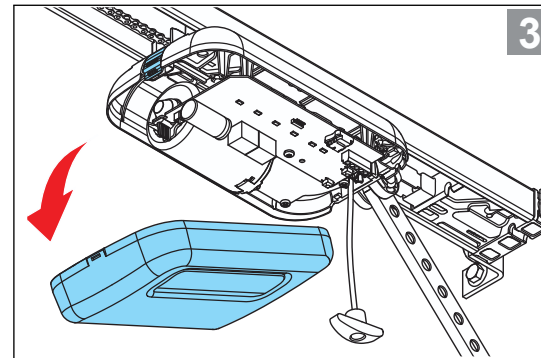
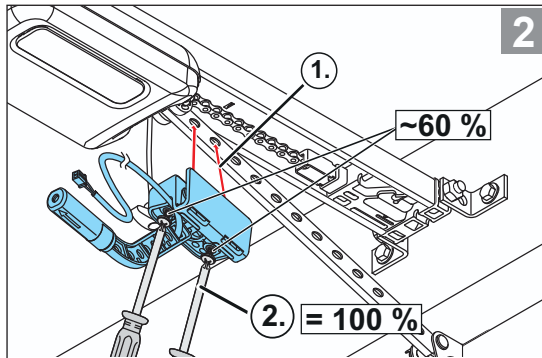
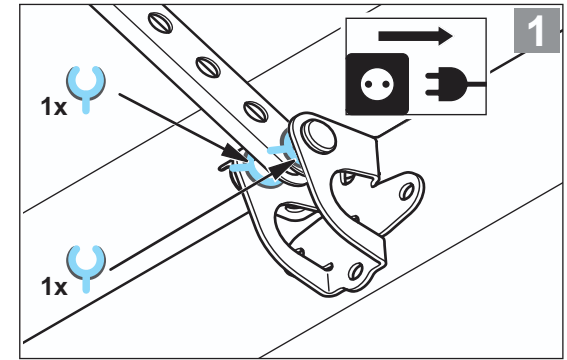
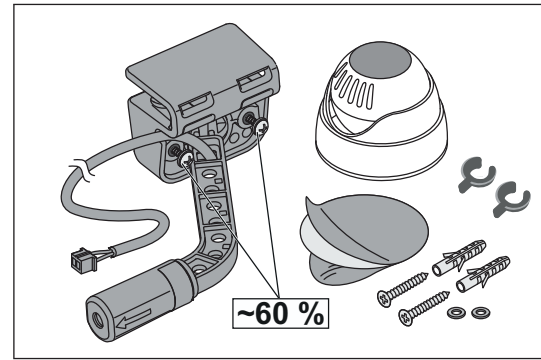
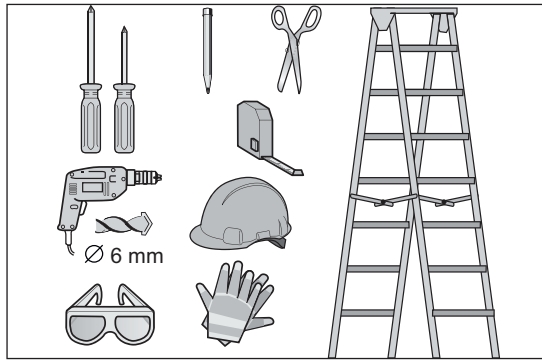

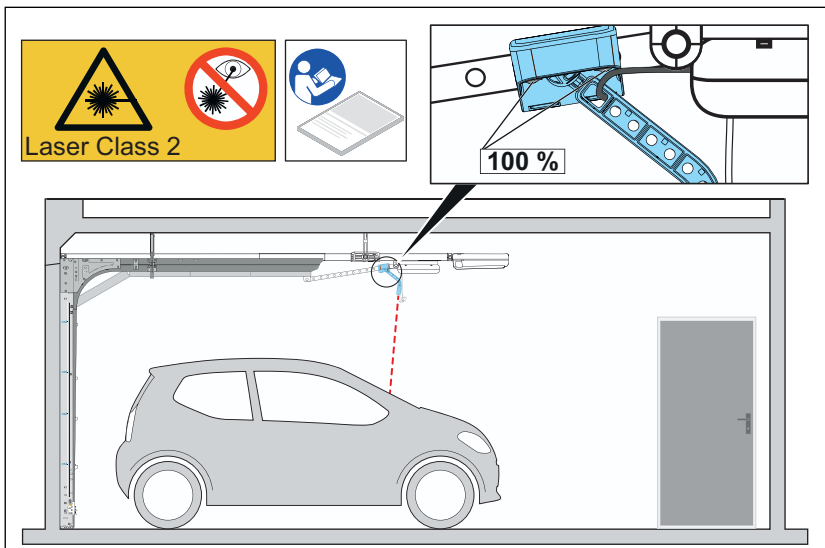

HINWEIS

Die Einstellungen des Lasers dürfen nicht verändert werden, z. B. durch Ball spielende Kinder. Die Garage nach Aus- oder Einfahrt schließen, um Veränderungen am Laser und damit verbundene Sachschäden zu vermeiden.

NOTE

The laser setting must not be changed, for example by children playing ball. Close the garage after driving in or out to prevent changes to the laser and damage associated with this.

REMARQUE

Ne pas modifier le réglage du laser, par ex. lorsque des enfants jouent au ballon. Fermer le garage après être entré(ee) ou sorti(e) pour éviter tout risque de modification du laser et les dommages matériels consécutifs.

AVVISO

Le impostazioni del laser non devono essere alterate (fare attenzione, ad esempio, a bambini che giocano a pallone). Dopo un'entrata o un'uscita, chiudere il garage per prevenire possibili alterazioni al laser e conseguenti danni materiali.

INDICACIÓN

Los ajustes del láser no deben modificarse, p. ej., por niños jugando con un balón. Cierre el garaje después de entrar o salir para evitar modificaciones en el láser y los correspondientes daños materiales.



INFORMATION

Der Laser entbindet den Fahrer nicht von der Sorgfaltspflicht, sein Umfeld zu beobachten und die notwendigen Abstände einzuhalten.



INFORMATION

The laser does not release the driver from the obligation to exercise diligence when observing the surroundings and abiding by the necessary distances between the vehicle and other objects.



INFORMATIONS

Le laser ne décharge pas le conducteur de son obligation de surveiller son environnement et de respecter les distances de sécurité.



INFORMAZIONE

Il laser non esonera il conducente dal suo obbligo di prestare attenzione all'area circostante e di mantenere le distanze minime richieste.



INFORMACIÓN

El láser no exime al conductor de la obligación de obrar con diligencia, de prestar atención a su alrededor y de mantener las distancias necesarias.